

**RESILIENT INSTALLATION GUIDELINES FOR WPC PRODUCTS**

---

**I. GENERAL INFORMATION**

These installation guidelines are for WPC products only. All instructions and recommendations should be followed for a satisfactory installation.

- Acclimation of material prior to installation is not required; however, the floor covering should be installed in a climate controlled environment with an ambient temperature range between 55°F - 85°F (13°C-29°C) or average temperature of 70°F (21.1°C).
- For installations involving 3 season scenarios, meaning, the dwelling or installed space is without climate control for extended periods during certain seasons of the year, the post installation temperature range allowed is an ambient room temperature between 32°F and 100°F (0°C- 37.7°C). This allowance is for floating floors only and does not apply to glue-down installations.
- Avoid exposure to direct sunlight for prolonged periods, doing so may result in discoloration. During peak sunlight hours, the use of drapes or blinds is recommended. Excess temperature due to direct sunlight can result in thermal expansion and UV fading.
- Install product after all other trades have completed work that could damage the flooring.
  - If cabinets are to be installed on top of the flooring (including islands), that area of material must be fully adhered to the subfloor (including an additional 2' beyond the cabinets and islands).
- To minimize shade variation – mix from several cartons when installing flooring.
- Inspect all flooring for damage before installing. Claims will not be accepted for flooring that has been cut to size and/or installed.
- Use cementitious patching and leveling compounds that meet or exceed maximum moisture level and pH requirements. Use of gypsum-based patching and/or leveling compounds which contain Portland or high alumina cement and meet or exceed the compressive strength of 3,000 psi are acceptable.
- Installation Methods: Floating (on, above or below grade) / Glue Down (on, above or below grade)
- Required perimeter expansion spacing for Floating or Glue Down installation is as follows:
  - For areas less than 2500 sq. ft. use 1/4" gap
  - For areas larger than 2500 sq. ft. use 1/2" gap.
- WPC flooring is waterproof and reliably secures the flooring panels on all four sides. However, excessive moisture in the subfloor could promote mold, mildew, and other moisture related issues like the trapping of moisture emissions under the flooring, which may contribute to an unhealthy indoor environment.
- Additional layer of 6 mil poly film or equal vapor retarder with a perm rating of .1 or less is recommended and may be used as an additional layer of protection.

# RESILIENT INSTALLATION GUIDELINES FOR WPC PRODUCTS

---

## II. SUBFLOOR INFORMATION

All subfloors must be clean, flat, dry, and structurally sound. The correct preparation of the subfloor is a major part of a successful installation. Subfloor must be flat: 3/16" in 10' or 1/8" in 6'.

### A. WOOD SUBFLOORS

Do not install material over wood subfloors that lay directly on concrete or over dimensional lumber or plywood used over concrete. Refer to ASTM F1482 for panel underlayment recommendations.

1. Do not apply sheet plastic over wood subfloors.
2. Basements and crawl spaces must be dry. Use of a 6 mil black polyethylene is required to cover 100% of the crawl space earth. Crawl space clearance from ground to underside of joist is to be no less than 18" and perimeter vent spacing should be equal to 1.5% of the total square footage of the crawl space area to provide cross ventilation. Where necessary, local regulations prevail.
3. **DO NOT** install over sleeper construction subfloors or wood subfloors applied directly over concrete.
4. All other subfloors - Plywood, OSB, particleboard, chipboard, wafer board, etc. must be structurally sound and must be installed following their manufacturer's recommendations. Local building codes may only establish minimum requirements of the flooring system and may not provide adequate rigidity and support for proper installation and performance.
5. If needed add an additional layer of APA rated underlayment, fasten and secure according to the underlayment manufacturer's recommendations.
6. Resilient flooring is not recommended directly over fire-retardant treated plywood or preservative treated plywood. An additional layer of APA rated 1/4" thick underlayment should be installed.

### B. CONCRETE SUBFLOORS

**NEW AND EXISTING CONCRETE SUBFLOORS SHOULD MEET THE GUIDELINES OF THE LATEST EDITION OF ACI 302 AND ASTM F 710, "STANDARD PRACTICE FOR PREPARING CONCRETE FLOORS TO RECEIVE RESILIENT FLOORING" AVAILABLE FROM THE AMERICAN SOCIETY FOR TESTING AND MATERIALS, 100 BARR HARBOR DRIVE, WEST CONSHOHOCKEN, PA 19428; 610-832-9585; HTTP://WWW.ASTM.ORG.**

- Floors shall be smooth, permanently dry, clean, and free all foreign material such as dust, wax, solvents, paint, grease, oils, and old adhesive residue. The surface must be hard and dense, and free from powder or flaking.
- If the adhesive residue is asphalt-based (cut-back), or any other type of adhesive is present, it must be removed by industry accepted methods such as mechanical removal or wet scraping.
- If a chemical abatement has been performed, use S3 Surface Prep EXT (or equivalent/comparable product) to remove any residual chemicals present. Once S3 Surface Prep EXT™ (or equivalent/comparable product) has been properly cleaned and removed, apply one coat of S3 Moisture Shield (or equivalent/comparable product) for additional protection.
- Adhesive removal through the use of solvents or citrus adhesive removers is not recommended. Solvent residue left in or on the subfloor may affect the new adhesive and floor covering.

**WARNING! DO NOT SAND, DRY SWEEP, DRY SCRAPE, DRILL, SAW, BEAD BLAST OR MECHANICALLY CHIP OR PULVERISE EXISTING RESILIENT FLOORING, BACKING, LINING FELT, ASPHALTIC "CUT BACK" ADHESIVES OR OTHER ADHESIVES.**

These products may contain either asbestos fibers and/or crystalline silica. Avoid creating dust. Inhalation of such dust is a cancer and respiratory tract hazard. Smoking by individuals exposed to asbestos fibers greatly increases the risk of serious bodily harm. Unless positively certain that the product is a non-asbestos-containing material, you must presume it contains asbestos. Regulations may require that the material be tested to determine asbestos content and may govern the removal and disposal of material. See current edition of the Resilient Floor Covering Institute (RFCI) publication Recommended Work Practices for Removal of Resilient Floor Coverings for detailed information and instructions on removing all resilient covering structures. For current information go to [www.rfci.com](http://www.rfci.com).

- Concrete slabs must be dry with no visible moisture.
- Required Moisture Testing - maximum moisture level per ASTM 1869 CaCl is 8 lbs. and ASTM 2170 In-situ Relative Humidity 90% per 1000 sq.ft. in 24 hours.

# RESILIENT INSTALLATION GUIDELINES FOR WPC PRODUCTS

---

- Do not install over concrete with a history of high moisture or hydrostatic conditions. Excessive moisture in the subfloor could promote mold, mildew, and other moisture related issues like the trapping of moisture emissions under the flooring, which may contribute to an unhealthy indoor environment. Vivid Floors does not warrant nor is responsible for damage to floor covering due to moisture related issues.
- pH level of concrete should be between 7-10.
- The final responsibility for determining if the concrete is dry enough for installation of the flooring lies with the floor covering installer.

**NOTE: IT MAY NOT BE THE FLOOR COVERING INSTALLER'S RESPONSIBILITY TO CONDUCT THESE TESTS. IT IS, HOWEVER, THE FLOOR COVERING INSTALLER'S RESPONSIBILITY TO MAKE SURE THESE TESTS HAVE BEEN CONDUCTED, AND THAT THE RESULTS ARE ACCEPTABLE PRIOR TO INSTALLING THE FLOOR COVERING. WHEN MOISTURE TESTS ARE CONDUCTED, IT INDICATES THE CONDITIONS ONLY AT THE TIME OF THE TEST.**

## LIGHTWEIGHT CONCRETE

All recommendations and guarantees as to the suitability and performance of lightweight concrete under resilient flooring are the responsibility of the lightweight concrete manufacturer. The installer of the lightweight product may be required to be authorized or certified by the manufacturer. Correct on-site mixing ratios and properly functioning pumping equipment are critical. To ensure proper mixture, slump testing is recommended.

- Lightweight aggregate concretes having dry densities greater than 90 lbs. per cubic foot may be acceptable under resilient flooring.
- Concrete slabs with heavy static and/or dynamic loads should be designed with higher strengths and densities to support such loads.
- Surface must be permanently dry, clean, smooth, free of all dust, and structurally sound.
- Perform Bond testing to determine compatibility of adhesive to the substrate. A primer can be utilized to promote adhesion. Three internal relative humidity tests should be conducted for areas up to 1000 sq. ft. One additional test, for each additional 1000 sq. ft.

**Radiant Heating:** Radiant-heated subfloor systems can be concrete, wood or a combination of both.

The heating systems components must have a minimum of 1/2" separation from the flooring product. The system must be on and operational for at least 2 weeks prior to installation to reduce residual moisture. Three days prior to installation lower the temperature to 65°F, after installation gradually increase the temperature in increments of 5°F to avoid overheating. Maximum operating temperature should never exceed 85°F. Use of an in-floor temperature sensor is recommended to avoid overheating. Contact the manufacturer of your radiant heating system for further recommendations.

- *Electric Radiant Floors:* consist of electric cables (or) mats of electrically conductive materials mounted on the subfloor below the floor covering. Mesh systems are typically embedded in thin-set. When embedding the system components, use cementitious patching and leveling compounds that meet or exceed Vivid Floor's maximum moisture level and pH requirements. Use of gypsum-based patching and/or leveling compounds which contain Portland or high alumina cement and meet or exceed the compressive strength of 3,000 psi are acceptable.
- *Hydronic Radiant Floors:* pump heated water from a boiler through tubing laid in a pattern under the flooring. Typically installed in channels under a wooden subfloor (or) imbedded in concrete slabs. Requires the installer follow a specific nailing pattern to avoid penetration of the heat system.

# RESILIENT INSTALLATION GUIDELINES FOR WPC PRODUCTS

## C. EXISTING FLOOR COVERINGS

Flooring can be installed over most existing hard-surface floor coverings, provided that the existing floor surface is fully adhered, clean, flat, dry, structurally sound and free of deflection.

- Existing sheet vinyl floors should not be heavily cushioned and not exceed more than one layer in thickness. Soft underlayment and soft substrates will compromise the product's locking ability as well as diminish its indentation resistance.
- Installation is **NOT** allowed over any type of carpet.
- Do **NOT** install over wood floors adhered to concrete.
- This product can be installed over existing ceramic/porcelain tile products with up to a 1/4 inch wide grout joint. If the grout joint width exceeds 1/4 inch, a cementitious patching compound should be used to fill the grout joint to make it smooth with the surface of the tile.
- Additional layer of 6 mil poly film or equal vapor retarder with a perm rating of .1 or less is recommended and may be used as an additional layer of protection.

## III. INSTALLATION

**Tools:** Tape Measure, Utility Knife, Jigsaw, Tapping Block, Rubber Mallet, Pull Bar, 1/4" Spacers, T-Square, Safety Glasses, Broom or Vacuum and, if necessary, tools for subfloor repair.

### FLOATING INSTALLATION

WPC flooring is designed to be installed utilizing the floating method. Proper expansion space 1/4" (6.35 mm) is required. Undercut all doorjamb. Do not fasten wall moldings and or transition strips to the flooring.

**Glue Down Installation:** WPC products are approved for glue down installation over approved wood and concrete substrates. Follow adhesive label application instructions. Install flooring into wet adhesive to achieve a permanent bond. Maintain 1/4" (6.35 mm) perimeter expansion space. Refer to adhesive label for moisture limits of the adhesive. Roll flooring immediately after installation with a 100 lbs. 3-section roller.

#### **Recommended Adhesive(s): Titebond 675**

If alternative adhesives are used, a bond test should be performed to ensure compatibility.

**Flooring patterns must be installed in a staggered (offset) pattern.**

## LAYOUT

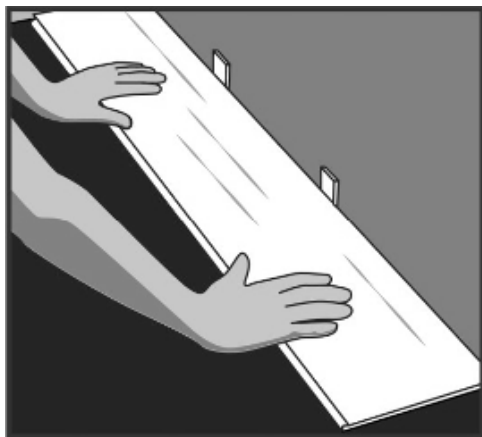

**Step 1:** Begin installation working from left to right. Insert spacers at ends and edges where flooring meet wall. Use

1/4" spacers along walls to maintain proper expansion space.

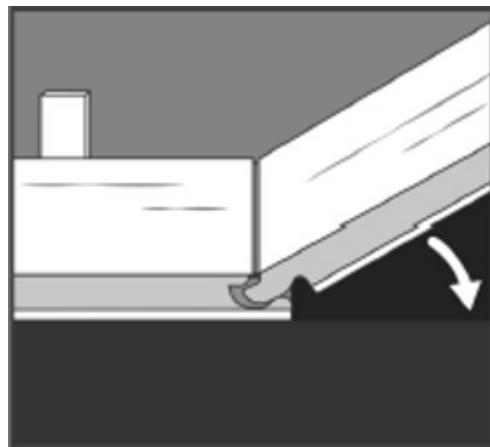

**Step 2:** Lock short end of flooring by inserting tongue into groove at an angle and drop in place. At end of the row, measure and cut the flooring to complete the row. Install the cut edge closest to the wall.

# RESILIENT INSTALLATION GUIDELINES FOR WPC PRODUCTS

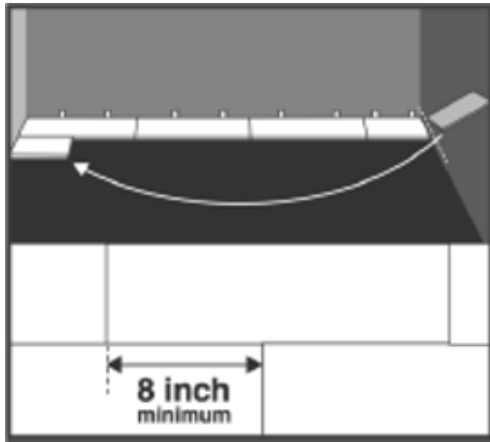

**Step 3:** Use leftover flooring from first row as starter for second row. There must be at least 8" (20cm) between flooring end joints on adjacent rows.

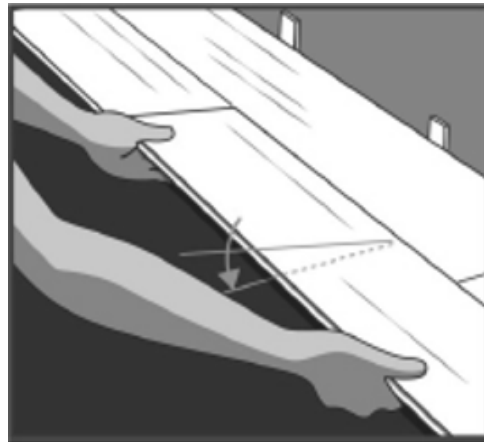

**Step 4:** Lock long edge of flooring by inserting tongue into groove at an angle and drop in place. Slide flooring toward end of previously installed flooring until the tongue just touches the groove.

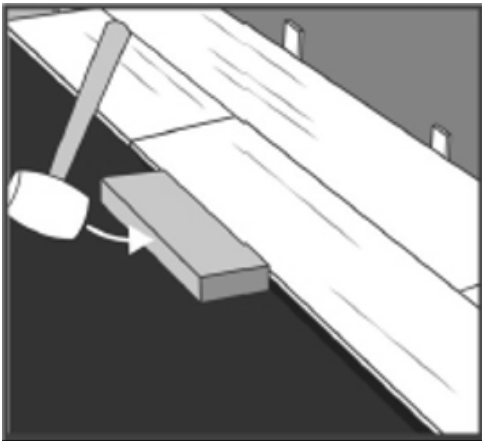

**Step 5:**  
**IMPORTANT!**  
Use rubber mallet and tapping block to tap long edge of plank to ensure a tight fit. **ANY GAPPING CAN COMPROMISE THE LOCKING SYSTEM!**

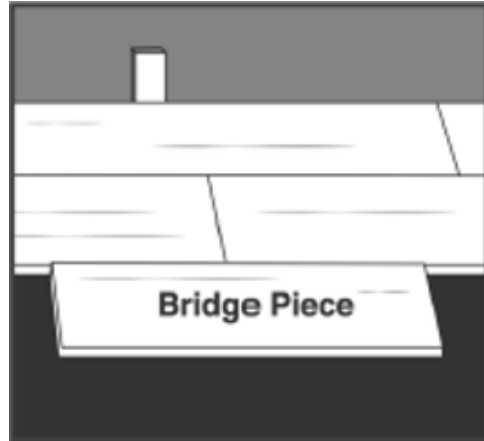

**Step 6:** Attach a scrap piece of floor to bridge the gap between ends of planks.

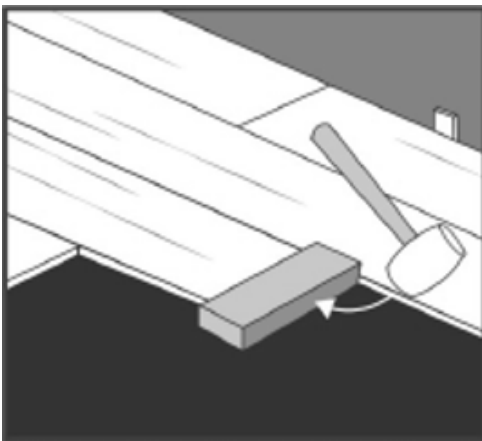

**Step 7:** Tap end of flooring with rubber mallet and tapping block to lock ends of flooring together. Remove bridge and continue towards wall until installing the final flooring in the row.

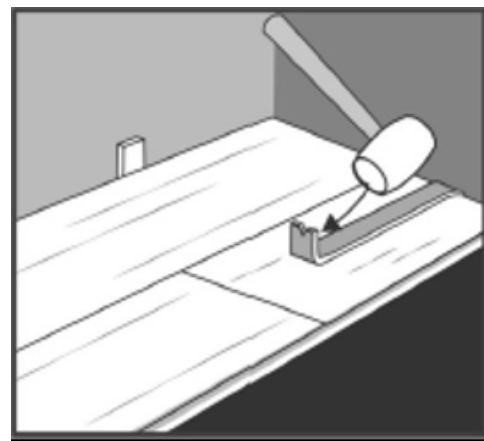

**Step 8:** Use rubber mallet and pull bar to lock final piece in row. Insert spacer at end of row. Continue installation to final row.

**BE SURE TO TAP ON EDGE OF VINYL SO AS NOT TO DAMAGE LOCKING PROFILE.**

# RESILIENT INSTALLATION GUIDELINES FOR WPC PRODUCTS

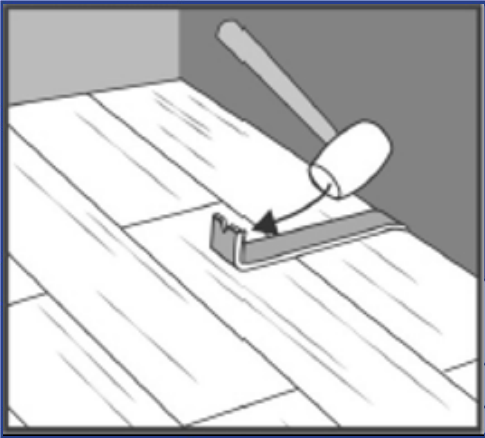

Step 9: Use rubber mallet and pull bar to lock long edges of flooring on final row.

## INSTALLING UNDERNEATH DOOR JAMBS:

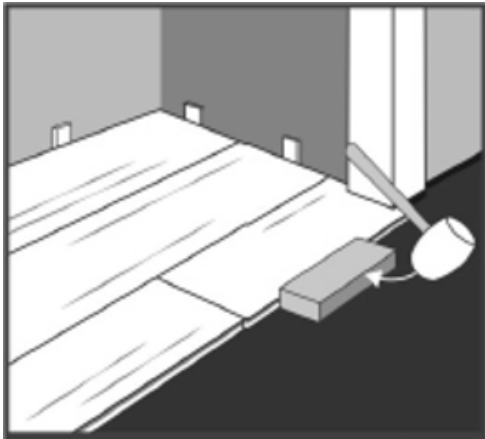

Step 1: Undercut space under door jamb to allow flooring to slide freely. Tap long edge with rubber mallet and tapping block to lock long edge.

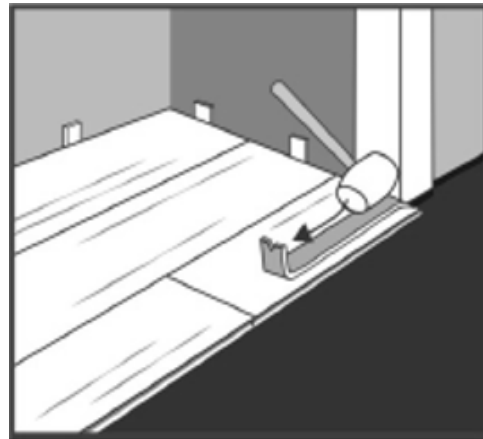

Step 2: Use rubber mallet and pull bar to lock this piece of flooring

## COMPLETION

- Protect all exposed edges of the flooring by installing wall molding and/or transition strips. Make sure that no plank will be secured in any way to the subfloor.
- For wet areas such as bathrooms caulk the perimeter of the floor with a flexible silicone caulk.
- Protect the finished flooring from exposure to direct sunlight to reduce fading and thermal expansion.
- Cutting resilient product into a fine point may lead to delamination. Use an ethyl cyanoacrylate based glue to help fuse the resilient point together. Be sure to clean all glue from the top surface immediately. Alcohol based glues may cause resilient products to swell.
- Adhering tape to the surface of your resilient flooring could damage the surface.  
**Do not** use tape to secure floor protection directly to the floor during construction or renovation. Instead, adhere tape to the material used to protect the floor and secure it to the base molding along the wall. A material such as ram board can also be used to protect your flooring.